

T 9060...
D 9960...
C 9860...
E 9860...

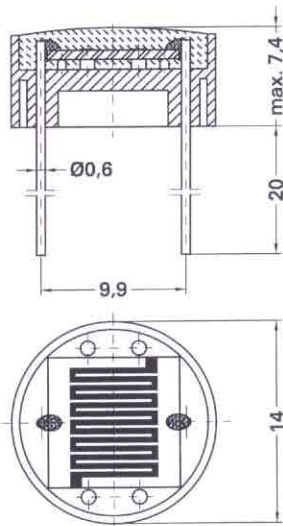

C 98...

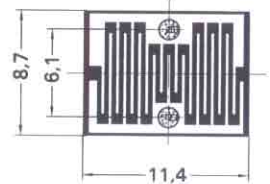
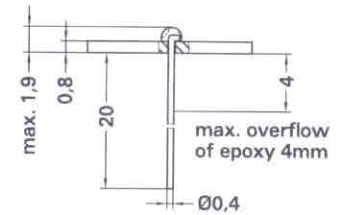
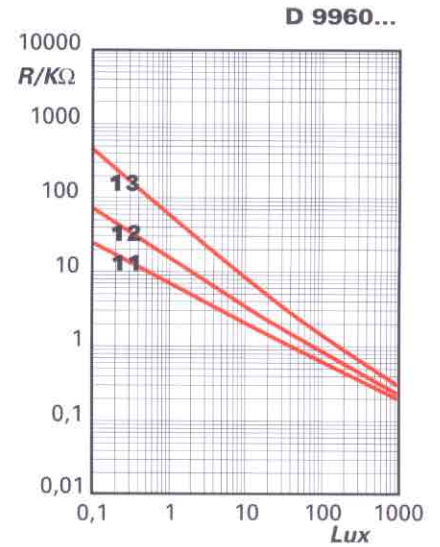
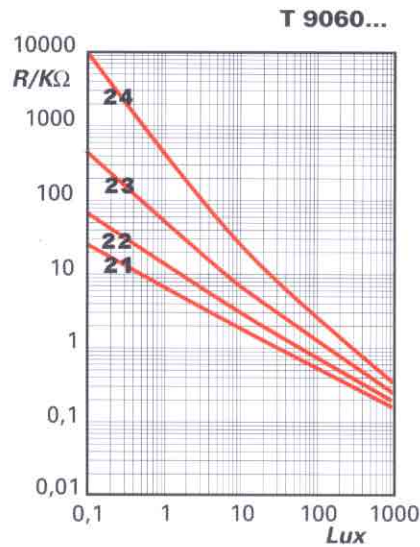

C 98...

Typical Electro-Optical Characteristics

Type	R 10 [kΩ]	R 100 typ. [kΩ]	R01 min. [MΩ]	R05 min. [MΩ]	$\gamma_{10/100}$ typ.	λ_{peak} [nm]
T 9060 21	0.9 ... 2.4	0.5	0.01	0.03	0.55	600
T 9060 22	1.8 ... 4.5	0.7	0.03	0.1	0.6	600
T 9060 23	3 ... 11	1.2	0.08	0.25	0.7	600
T 9060 24	10 ... 50	3.0	0.5	1.5	0.8	600
D 9960 11	1.5 ... 3.0	0.6	0.01	0.03	0.6	600
D 9960 12	2.8 ... 6	0.8	0.03	0.09	0.7	600
D 9960 13	4.5 ... 13	1.5	0.1	0.3	0.8	600
D 9960 21	4 ... 9	1.8	0.03	0.09	0.6	600
D 9960 22	8 ... 15	2.5	0.09	0.27	0.7	600
D 9960 23	12 ... 35	4.0	0.5	1.5	0.8	600
C 9860 22	1.5 ... 7	0.7	0.2	0.6	0.7	600
C 9860 23	5 ... 12	1.5	0.2	0.6	0.75	600
E 9860 23	5 ... 12	1.5	0.5	1.5	0.75	600

*customized selections available on request

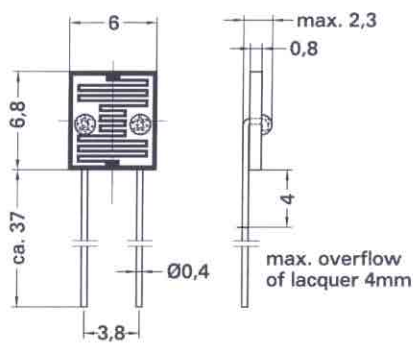
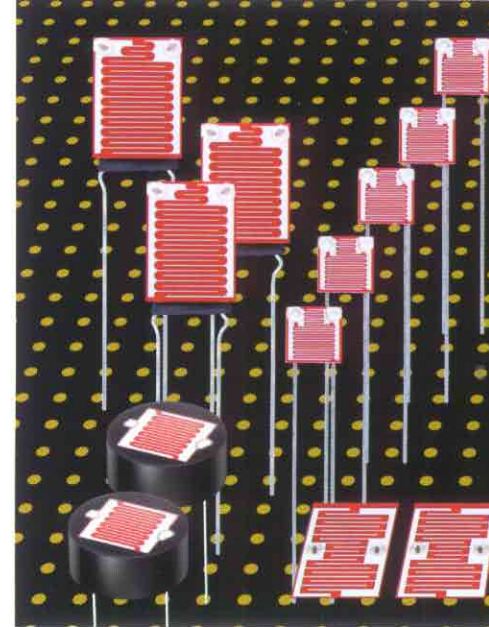
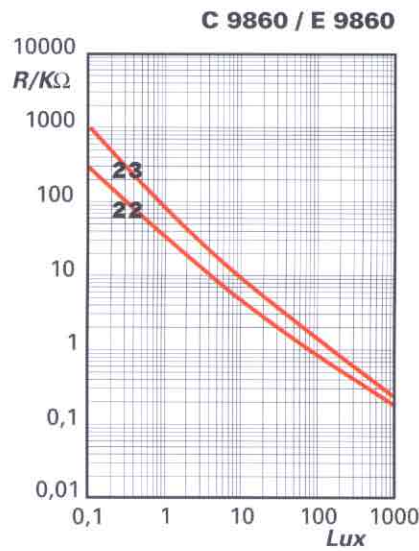
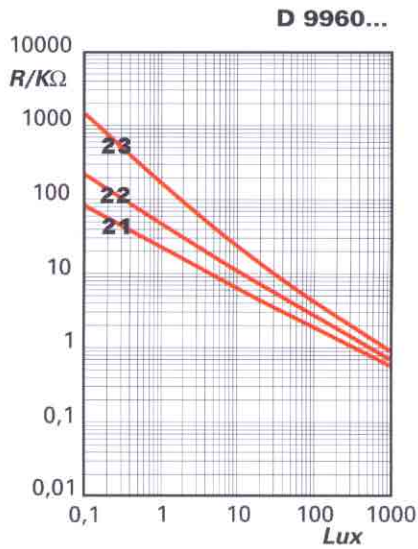

D 99...

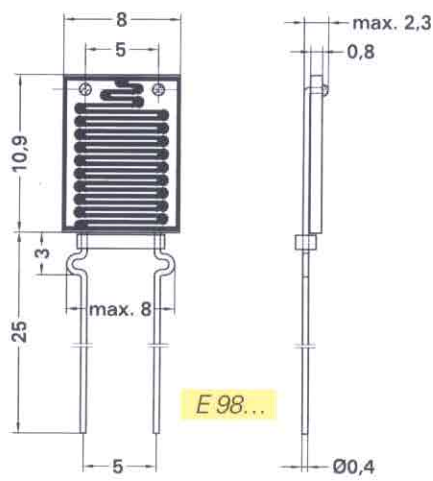

E 98...

Limit Values

Top range [°C]	T _{st} range [°C]	TC 10 lux [%/°K]	t _{on} typ. [msec]	t _{off} typ. [msec]	V _{max} [V]	P _{max} [mW]
-20 ... +70	-20 ... +80	0.3	60	40	200	200
-20 ... +70	-20 ... +80	0.35	50	40	200	200
-20 ... +70	-20 ... +80	0.35	50	35	200	200
-20 ... +70	-20 ... +80	0.4	35	30	200	200
-20 ... +70	-20 ... +80	0.3	60	35	150	200
-20 ... +70	-20 ... +80	0.35	50	30	150	200
-20 ... +70	-20 ... +80	0.4	35	25	150	200
-20 ... +70	-20 ... +80	0.3	60	35	150	200
-20 ... +70	-20 ... +80	0.35	50	30	150	200
-20 ... +70	-20 ... +80	0.4	35	25	150	200
-20 ... +70	-20 ... +80	0.3	50	40	150	400
-20 ... +70	-20 ... +80	0.4	40	30	150	400
-20 ... +70	-20 ... +80	0.4	40	30	150	300